

Optimising the productivity of lifting appliances

Anti-Sway: controlling the swaying of the load

January 2010 / White paper

by Jacques Piriou

Summary

Foreword.....	p I
Introduction.....	p II
When automation surpasses human actions	p II
Classification of Anti-sway devices	p III
Description of the phenomenon	p 01
The pendular movement set out as equations	p 01
Principle of the Anti-Sway device.....	p 02
Practical operation	p 02
The brain of the device	p 03
Implementing the Anti-Sway device.....	p 04
Using existing equipment	p 04
Conclusion.....	p 06
Movement under control	p 06

Foreword

Handling loads is an essential operation in all human activity. Moving and transporting objects is part of the daily life of anybody who is in the industrial sector.

In the manufacturing and distribution sectors, this operation is very often done using handling equipment, such as overhead travelling cranes or gantry cranes controlled by hoist operators and it is not uncommon for load-moving to take up 20% of the production cycle.

Thus, load-moving often determines the consistency of the production cycle. In order to limit fragmentation of the cycle, it is therefore vital that these handling periods are:

- as short as possible,
- as consistent as possible.

Which cannot happen without a device to help to control the swaying of the load.

OEM's which offer this device have an undoubted competitive advantage.

Introduction

When automation surpasses human action

With an overhead travelling crane or a gantry crane the load is suspended from a gripping device by cables and becomes a pendular device.

Inevitably, when the handling equipment starts to move, the balance of this load is upset and the swaying thus generated poses control and positioning problems. Without corrective action, only friction will limit the extent of this and deaden this swaying. With no particular device to do this, controlling this swaying depends solely on the skill of the driver of the machine who manually applies a counter reaction to the movements of the load.

For automatic loading and unloading systems or with a novice operator, this phenomenon considerably upsets the cycle time.

Experimentally, when an overhead travelling crane controlled by an operator reproduces the same cycle a sufficient number of times, the analysis shows that the cycle lengths are distributed following a Gausse curve. Most loads will be transferred in an average time, with correct and poor operations equally distributed on both sides of the curve (black curve 1). By repeating the same test with an anti-sway system, the dispersion and the time are reduced (curve 2 – blue) which means that the movements are being performed more accurately and more quickly.

When the movements are automated, they are always repeated more briefly with reduced dispersion. The result is a distribution in which all the load transfer movements take place in an identical manner and almost optimally (green curve 3).

In addition, the anti-sway device brings the following advantages :

- protection of the load and the machinery and less maintenance,
- lower risk of accidents,
- lower operator fatigue. The lifting equipment can be used safely by novice operators,
- lower cycle times (up to 25%), particularly for automatic machines and, indirectly, lower energy costs.

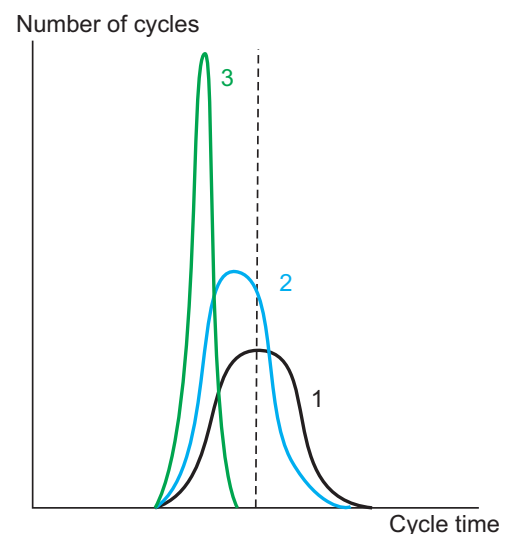

Introduction

Classification of Anti-sway devices

Anti-sway systems come under three main categories:

- passive systems: cables attached to the load prevent it from swaying,
- active closed loop systems where the swaying angle is measured with a camera connected to an image processing system,
- active open loop systems where the information is obtained without additional sensors, from the information available.

The first system entails mechanical complexity and permanent maintenance. The second requires costly auxiliary systems and case by case adjustment. The third is by far the simplest and the easiest to implement.

The Anti-Sway solution, provided by Schneider Electric, belongs to this last category. It provides a powerful, economic, maintenance-free response with no need to modify equipment.

The originality of this approach is that it works without measuring the actual swaying, by means of an estimator embedded in a drive controller or any external logic controller.

The principle is that the anti-sway controller calculates an acceleration (a progressive speed profile) that enables the lifting equipment to reach a given movement speed without the load swaying.

Since there is no way to determine the actual state of the physical system, proper operation requires a zero initial swaying and insignificant external disruptions, such as wind.

The installation of an active open loop anti-sway system has an undoubted economic advantage compared with a closed loop system.



Anti-Sway:
controlling
the swaying
of the load

Description of the phenomenon

The pendular movement set out as equations

The diagram opposite represents a lifting appliance with its load suspended on the trolley by one or several steel cables which normally move backwards and forwards on return pulleys between the trolley and the gripping tool.

This load has to be moved following the X and Y axes from a point (A) and be placed at a point (B).

The load undergoes terrestrial acceleration on the one hand and the horizontal acceleration of the trolley on the other hand; it is thus subject to a pendular movement and swaying in accordance with the following simplified expression: $T = 2\pi\sqrt{L/g}$

In this expression:

- T is the period of oscillation

- L is the distance between the hoisting drum of the lifting appliance and the centre of gravity which includes the load, the hook-up device and the cable

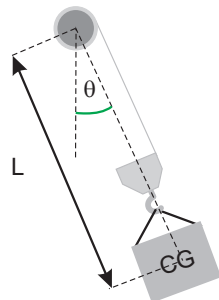

- g is the gravitational acceleration

It must be noted that this period and the pendulum angle thus created are not affected by the mass of the load. On the other hand, the position of the centre of gravity is the determining factor that modifies the swaying period.

At all times the position of the load is perfectly defined if the position of the trolley, the position of the load's centre of gravity (L) and the angle (θ function of time) made by the pendulum with the vertical are known.

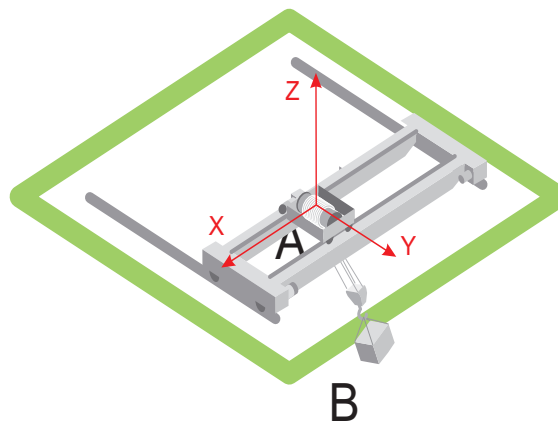
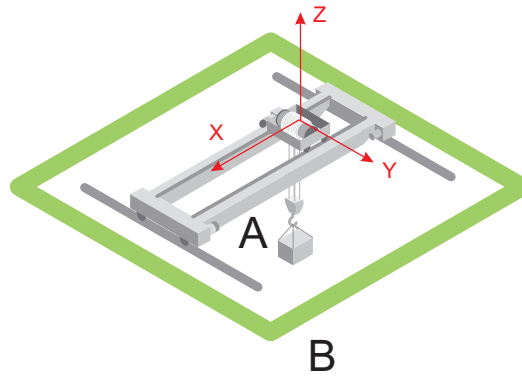

In order to ensure that the operator can deposit the load accurately, the pendulum swaying must be as weak as possible.

Ideally:

$$\theta = 0, d\theta/dt = 0$$

The diagram below represents the angle of the load which is roughly a deadened sinusoid.

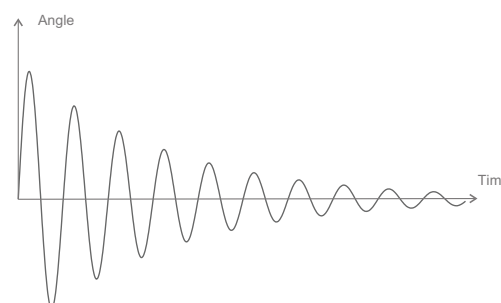

Principle of the Anti-Sway device

Practical operation

To prevent violent operation, the variable speed drive have a progressive speed setting system which has the effect of optimising acceleration. These speed settings can be adjusted in terms of time and shape (linear, S curves etc.) to suit most applications.

The diagram opposite represents the variable speed drive ramps with and without the Anti-Sway function. The ramp in the speed setting, linear in black, cannot be adjusted automatically and, because of this, the operator is left to control the swaying.

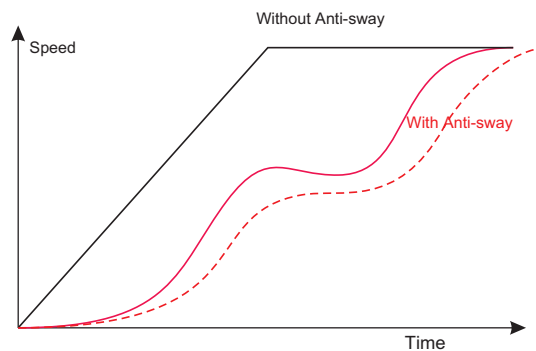

The Anti-Sway function (red curve on the speed/time graph), helps the operator to do this by ensuring that the acceleration or deceleration profile of each movement is adjusted in real time to the estimated position of the load. On this diagram we have only represented two profiles but, in practice, an infinite number of profiles is conceivable.

On the right of the graph opposite, the red curve represents the speed profile as it is generated by the Anti-Sway function; the green curve the difference in angle between the load and the vertical.

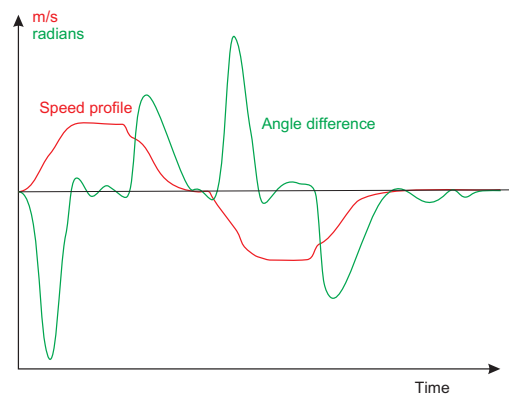

The position estimator carries out a sampling procedure every 40 ms (typical value) for each movement. You can see distinctly that the initial angle difference is rapidly controlled by the device as soon as the speed has stabilised.

Each change in speed inevitably destroys this balance but the speed profile very rapidly controls this difference. At the end of the movement, an adjustable time out enables the load to be stopped and deposited under the best conditions.

Principle of the Anti-Sway device

The brain of the device

Without the corrective actions of an experienced operator, returning to a stable state of equilibrium may take several seconds.

The swaying of the load only appears during the linear motion of the gantry crane (x movement) or when the trolley moves (y movement).

Lifting the load following the z axis does not generate any swaying.

The Anti-Sway principle is based on using a load position estimator which at all times solves the equation:

$$\theta = \theta_0 \cos \sqrt{L/g}$$

and determines the difference between the perpendicular and the trolley.

It will be noted that in this equation the length L incorporates the position of the centre of gravity.

The Anti-Sway device uses the following information:

- the translation speed of the two horizontal axes, i.e. the speed of the gantry crane (dx/dt) and that of the trolley (dy/dt),
- the acceleration and deceleration speeds of these same axes (d^2x/dt^2 and d^2y/dt^2),

- the length of the cable,
- the position of the centre of gravity.

The position of the centre of gravity is a variable figure that depends on the geometry of the load that the operator has to fill in.

The swaying of the load is controlled by variable speed drive that adjust the translation and trolley movements by adapting the rate laws constantly.

The useful information (speed, acceleration, if necessary length of the cable from a sensor connected to the motor) is directly accessible from the variable speed drive or using externally connected equipment (for example length of the cable by a cam box).

From a configurable model the estimator calculates the expected swaying of the load by taking account of the information available in the controller, the length of the cable and the position of the centre of gravity.

Implementing the anti-sway device

Using existing equipment

With advanced variable speed drive it is possible to integrate the swaying control function by using a specific card. It works by automatically recognising the controller and takes control of everything using a field bus. The same electrical operating interface can be used without any modifications to the cabling required.

This function can also be performed in a remote controller.

The safety areas are controlled by position switches (deceleration and stop switches).

Implementation examples:

- the anti-sway function is incorporated into an automated control system or a remote controller.

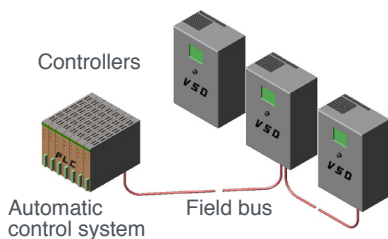

- the anti-sway function is integrated into one of the machine controllers

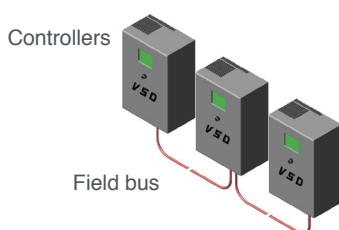

The controller continuously calculates the speed ramp, also called the speed profile, to stop the swaying.

In the most case, a variable speed drive with sensor is used for the lifting and variable speed drive without sensor are used for traveling and trolley axis. The anti-sway card is preferably integrated into the lifting variable speed drive in order to obtain information from the sensor and give the speed profiles to the others by means of a field bus, for example CANopen.

However, as the system is an open loop system, the correction can only work if the initial swaying is zero and, as already mentioned, if there is no disruption that is not associated with the movement, such as wind. If these conditions are not met, the Anti-Sway function may be disabled to avoid unsuitable corrections.

Implementing the anti-sway device therefore does not require the lifting appliance to be modified in any way. The presence of variable speed drive on each translation movement is the only vital condition. The anti-sway function may be installed originally by the manufacturer of a new machine or easily adapted to an existing machine.

Several installation methods are possible depending on the equipment and the control method, i.e. the generation of speed instructions and the possible presence of a sensor on the lifting movement.

The speed instructions for a lifting appliance are normally generated by:

- control boxes (normally two preset speeds),



Implementing the anti-sway device

- manipulators (normally 4 speed), right/left, forward/ back, up/down,
- continuously (analogue voltage supplied by a control card or a potentiometer).

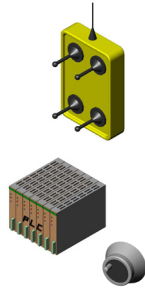

The length of the cable may be measured in various ways:

- manually with a three position switch thus selecting the pre-determined cable values,
 - ♦ LP low position
 - ♦ MP medium position
 - ♦ HP high position

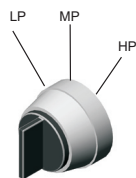

- automatically by a cam box with two position detectors that determine three cable lengths,

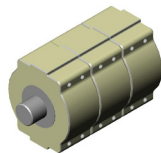

- continuously using an encoder, normally the one connected to the motor,

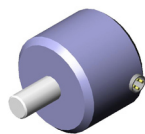

The anti-sway device is adjusted simply by connecting to the inputs of the corresponding function modules.

As an example, we shall describe the implementation of the cable length function.

Below we shall assume that the lifting movement is equipped with a cam box. This cam box, which is interdependent with the hoisting drum, contains two switches (Llx and Lly) which determine three work areas.

The cams will be adjusted in order to delimit roughly equal sectors.

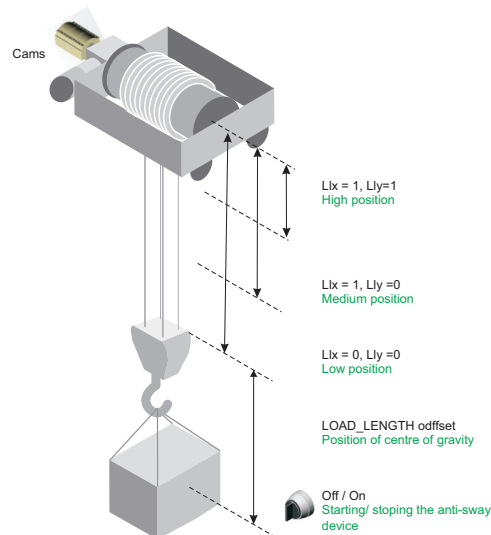

All that will be necessary will be to connect the switches to the corresponding inputs of the function module and to configure the position of the load's centre of gravity.

A dual position switch disables the anti-sway function.

Implementing the anti-sway device

This type of device can be used for a moderate lifting range (about 10 metres). It is advisable not to exceed 2 metres for each of the operating ranges.

For example, the low position will be equal to 10 metres, the medium position 8 metres and the high position 6 metres.

The anti-sway device works entirely automatically and does not require any intervention on the part of the operator.

For lifting movements greater than 10 metres an encoder must be used.

In this case the length of the cable is known precisely and the swaying is controlled with the greatest delicacy.

However, whatever the solution used, the operator has to fill in the position of the centre of gravity.

In practice, the variations in load geometries are slight and the adjustments required as a result of this are limited.

The anti-sway function also includes management of the deceleration limit switches and movement limit switches for each movement. Therefore safety of operation is always assured, permanently and reliably.

Conclusion

Movement under control

For lifting appliances installed in factories and warehouses sheltered from the wind, the anti-sway device provides the best price/ performance ratio.

For a minimum investment, the learning time is considerably reduced, the operating cycles no longer depend on the dexterity of the operator and the dispersion of cycle times is reduced significantly.

Load-moving is no longer, as was often the case, a bottleneck affecting productivity and the return on investment is almost immediate.

Initially, open loop operation, which requires the movement to be started with an immobile load, may be taken as a restriction, but it is the normal situation under actual conditions.

In fact, the cargo hook has come down directly over the load and the lifting has not caused any swaying. An initial load swaying condition can only be due to an accidental action which is easily controllable.

Operating hazards, the risks of the load or the equipment being damaged as well as dangers to operators are considerably reduced.

Automatic operation is conceivable and operators can be sure that production requirements will be observed completely safely.

Controlling swaying by a device with no sensor is a necessity understood by a large number of OEM's and users.

It is used to observe the regularity of cycles reliably and completely safely.

A significant reduction in handling time is achieved without tedious learning processes, which results indirectly in less energy being consumed.

Schneider Electric SA

35 rue Joseph Monier
F-92500 Rueil Malmaison - France
Phone: + 33 (0) 1 41 29 70 00
Fax: + 33 (0) 1 41 29 71 00
<http://www.schneider-electric.com>