

Automation 2000

*Machines access
the web*

May 2000



Schneider
 **Electric**

Get more with the world's Power and Control Specialist !



The Automation Business Unit



**Chairman and CEO
H. Lachmann**

**Vice-Chairman and COO
J.P. Jacamon**

**Strategic Business Units
J.P. Saas**

**Schneider Electric.net
E. Pilaud**

**Geographic
Divisions
France
M. Torrents**

**Europe
C. Wiest**

**North America
C. Richardson**

**Rest of the world
J.L. Andreu**

**Medium Voltage
J. Kieffer**

**Low
Voltage
J.P. Chardon**

**Industrial
Control
J. Karecki**

**Automation
& Num
A. Marbach**



Global leadership positions in our core businesses

Medium voltage	Low voltage power distribution	Low voltage final distribution	Industrial control	Automation
ABB	1 Schneider Electric	1 Schneider Electric	1 Schneider Electric	Siemens
2 Schneider Electric	Mitsubishi	ABB	Rockwell	Rockwell
Alstom	Eaton	Siemens	Siemens	3 Schneider Electric





MODICON

Number 2
in the USA

 **Telemecanique**

Number 2
in Europe

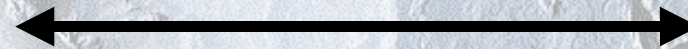

Some of our international customers...
DaimlerChrysler - Bristol Myers Squibb



Our theme... today
the Internet
“Machines also
want to access the Internet”

Transparent
FACTORY™
Open for Business





1969 Modicon foundation

1974 Apple Computer foundation

1996 Schneider Electric owns 100% of AEG-S-Automation

1996 first statement for Ethernet from Schneider Electric

1996 first web patents

October 1998 first products

1999 100 MF Revenues

The old hierarchy for Automation Systems

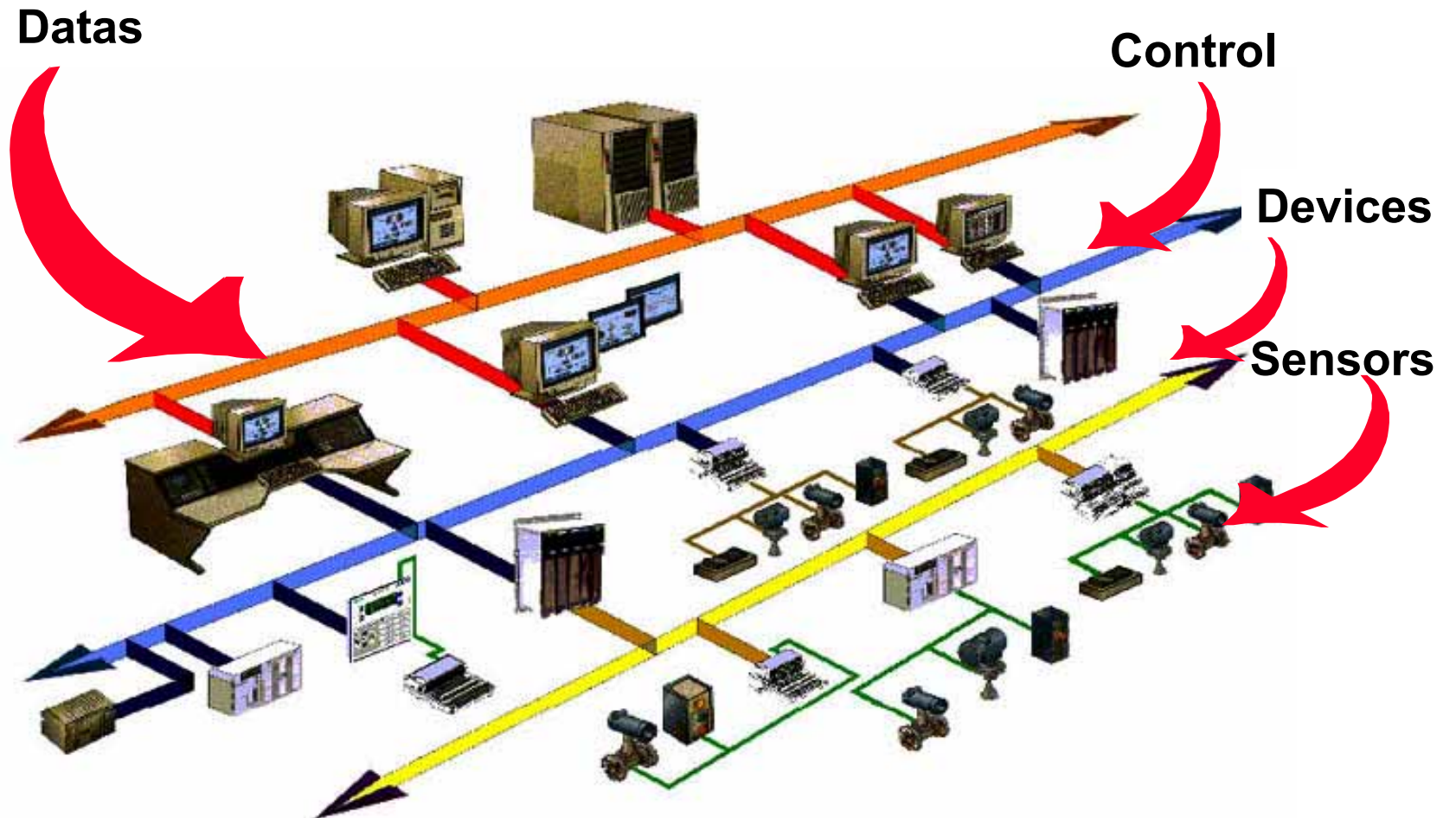

The new structure Ethernet everywhere ... Internet everywhere

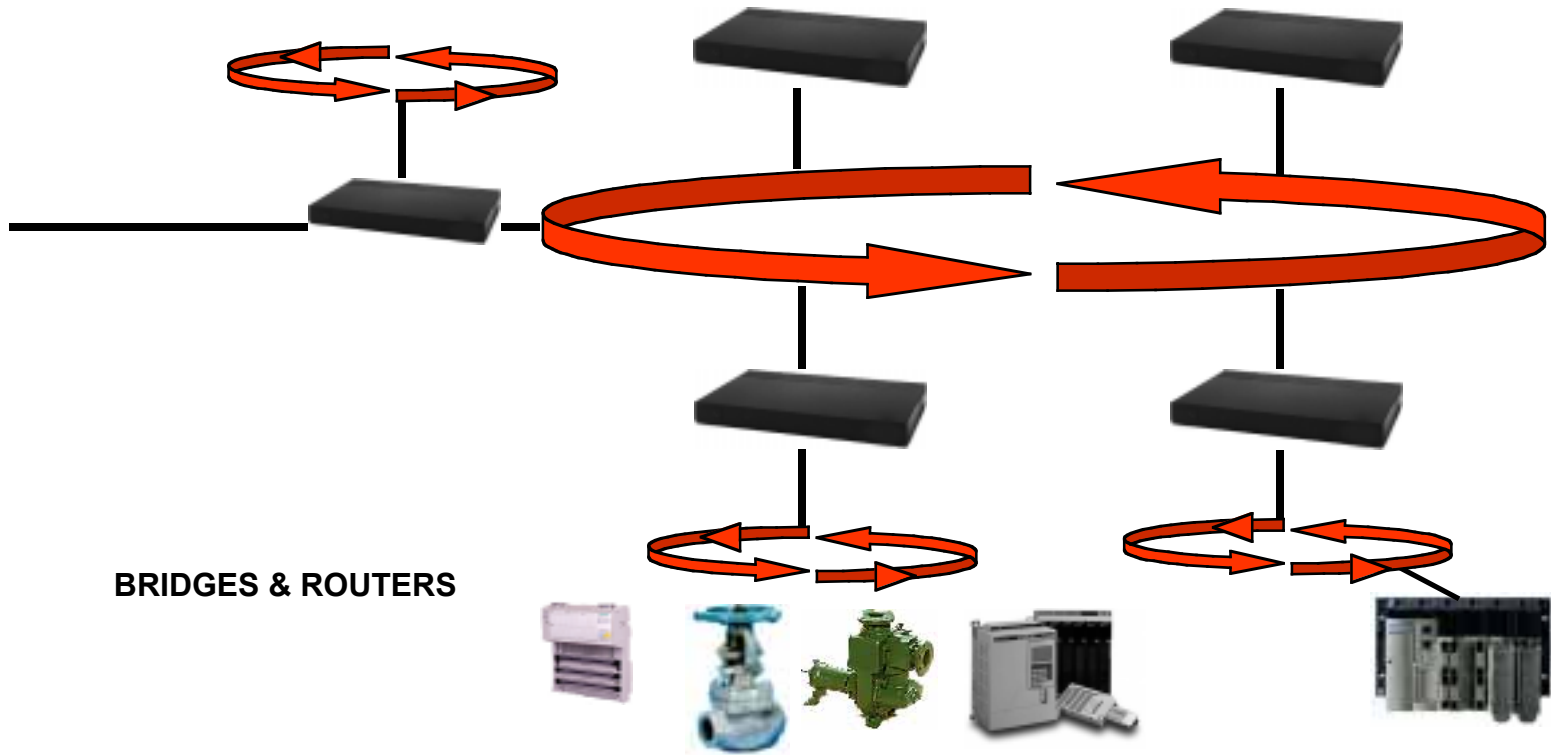
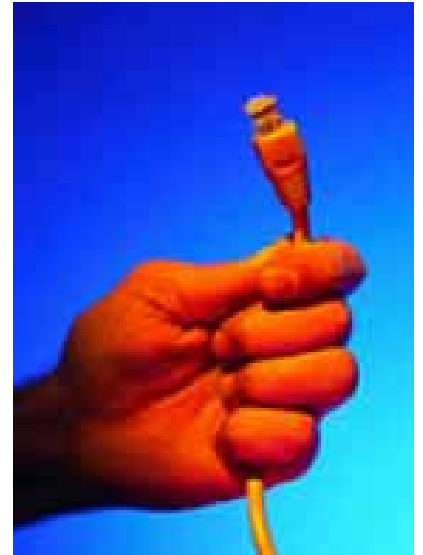

BRIDGES & ROUTERS



And Web servers everywhere ...

Transparent
FACTORY™
Open for Business

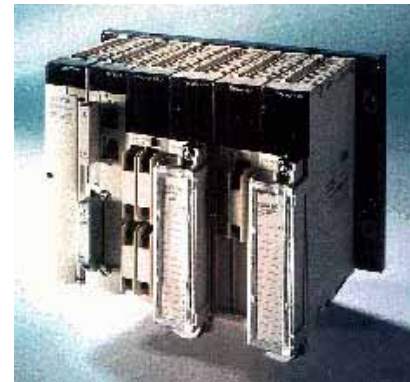

What is a Web server for a Programmable Logical Controller ?

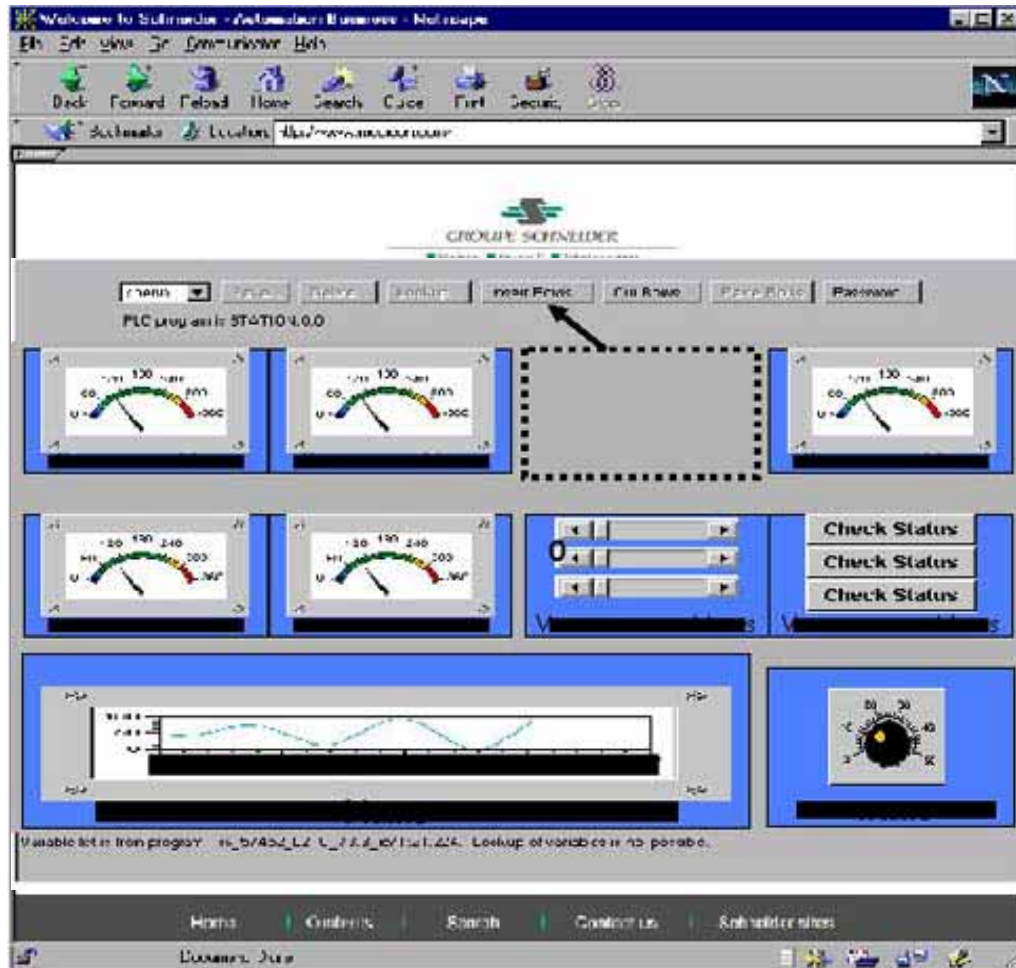

A welcoming page...
...customizable...

Which can download
applets... Automation's

Transparent
FACTORYTM
Open for Business



What are Customers benefits ?

**An immediate benefit ...
the availability of all informations without programming
in particular in the maintenance field**

maintenance



What are Customers benefit - Maintenance ?

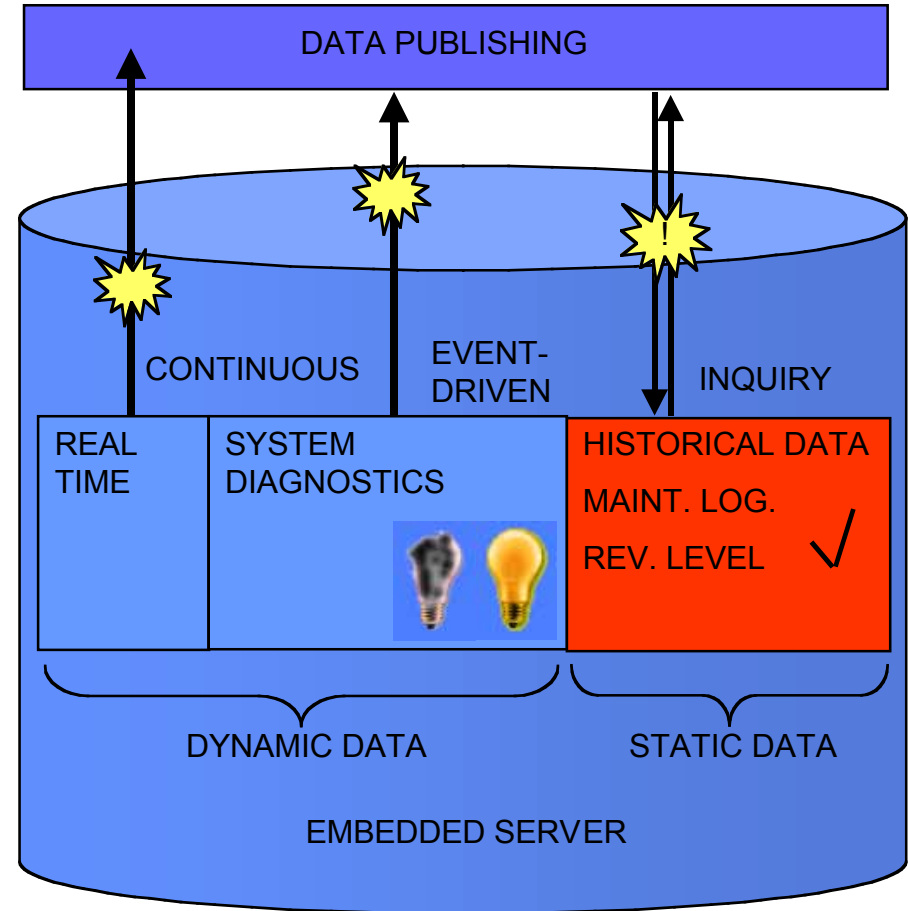
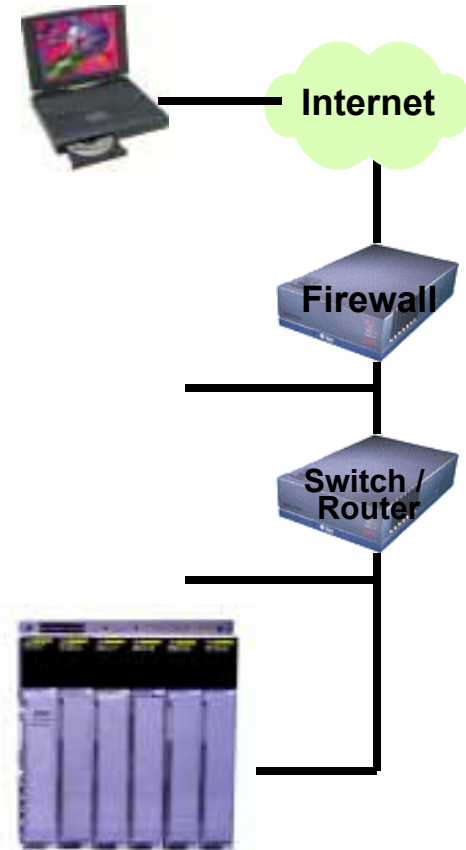

What are Customers benefits ?

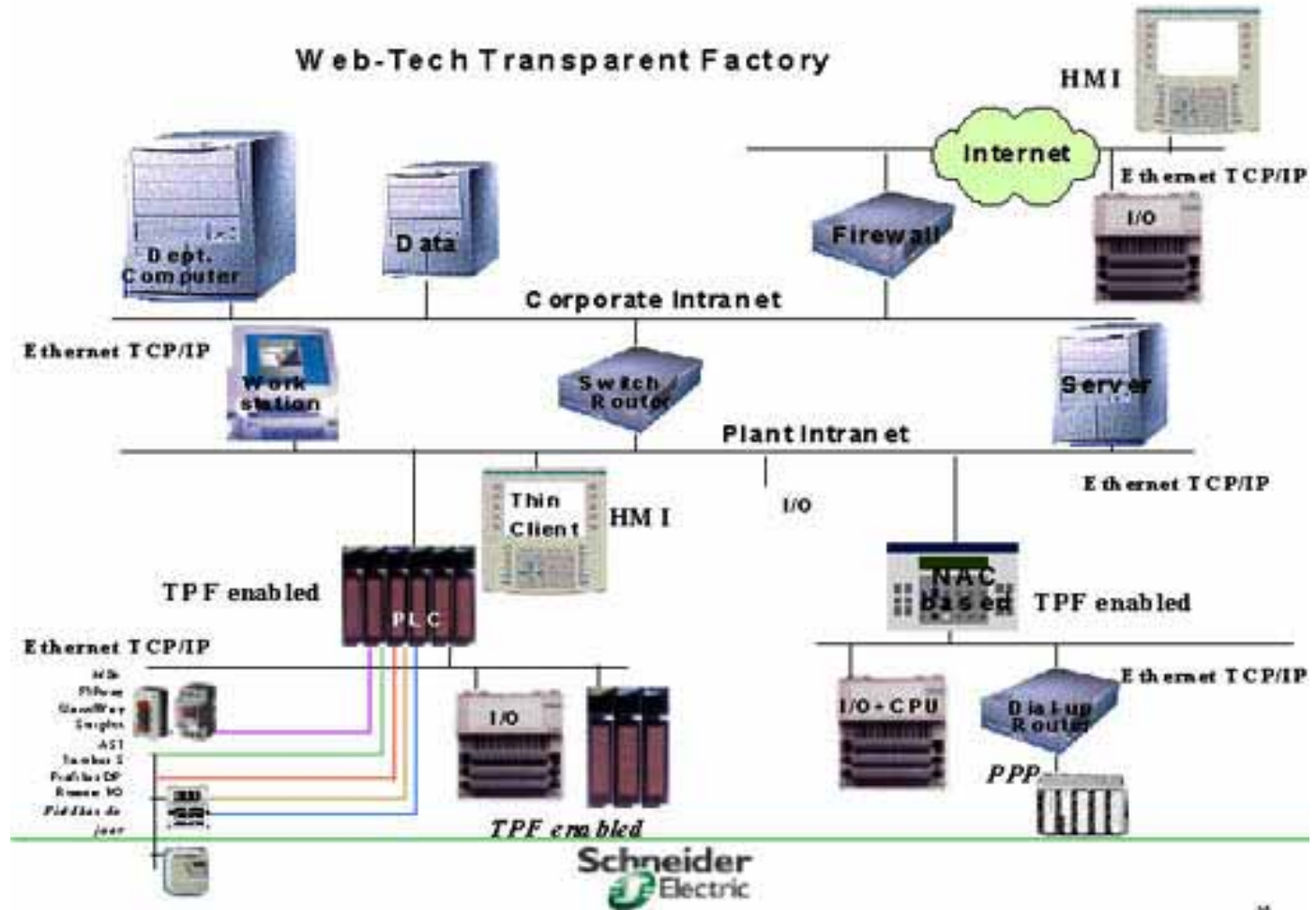

What are Customers benefits ?

**An immediate benefit...
the availability of all informations without programming
in particular in the maintenance domain**

maintenance

process data



What are Customers benefits ?

**A global benefit...
the usage of largely used technologies...
as deep as possible within the manufacturing environment**



easy training

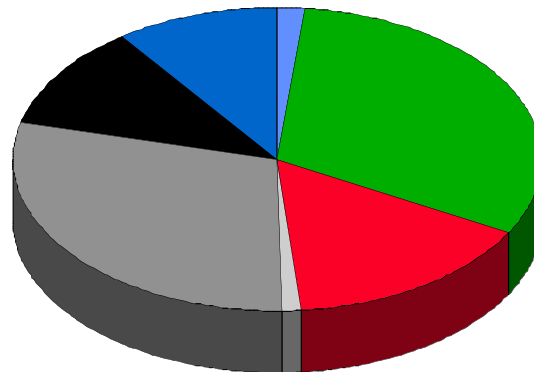

■ Modbus + ■ Interbus ■ Profibus ■ Devicenet
■ Lonworks ■ Seriplex ■ Asi

Donnees intentionnellement inexactes

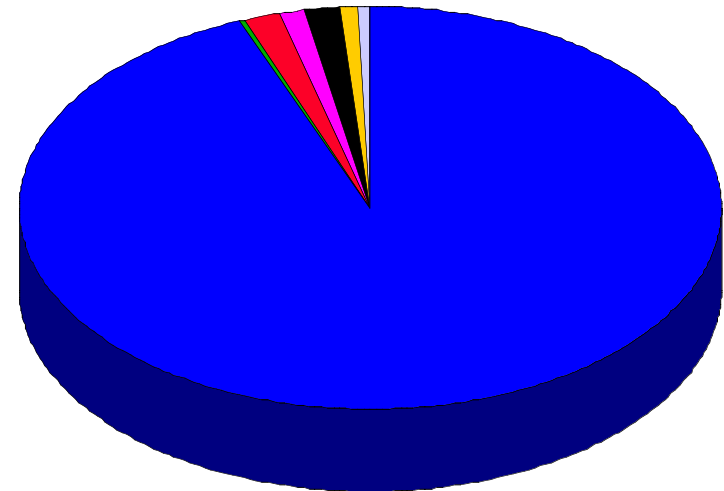

■ TCP/IP ■ Modbus + ■ Profibus
■ Devicenet ■ Lonworks ■ Seriplex ■ Asi



What are Customers benefits ?

A global benefit...
 the usage of largely used technologies...
 as deep as possible within the manufacturing environment

easy training

easy evolution



Ethernet Switch= Scalable Architecture

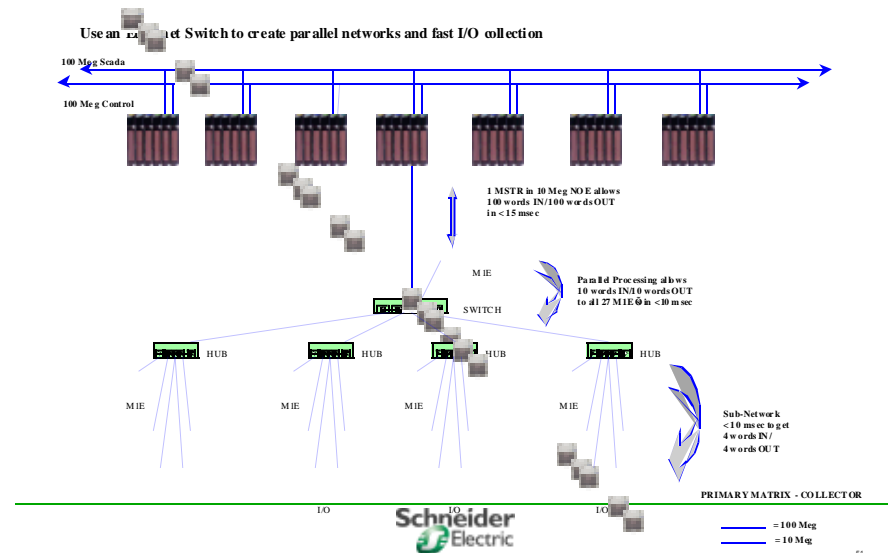

What are Customers benefits ?

**A global benefit...
the usage of largely used technologies...
as deep as possible within the manufacturing environment**

easy training

easy evolution

easy connection to the accounting world



Some 1999 Success Stories

Metro de Lyon:

a real time monitoring and control network for the Metro station in Lyon. Using the commercially available Ethernet technologies.

Wartsila Diesel:

Global coverage on their power station for preventive maintenance and monitoring purpose, saving thousands of dollars in traveling and post mortem repair cost.

UPS:

A parcel sorting station for 50 000 packages per hour. High speed and accuracy to control and link the sorting system to order processing and tracking mechanisms.

IBM:

Semiconductor fabrication. Ethernet integration solution for fault detection an yield enhancement.



Where will we push our limits now ?



By enabling the devices, information access becomes easier and globally-accessible

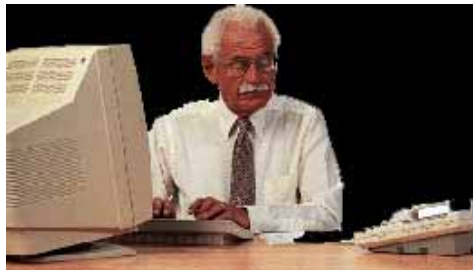
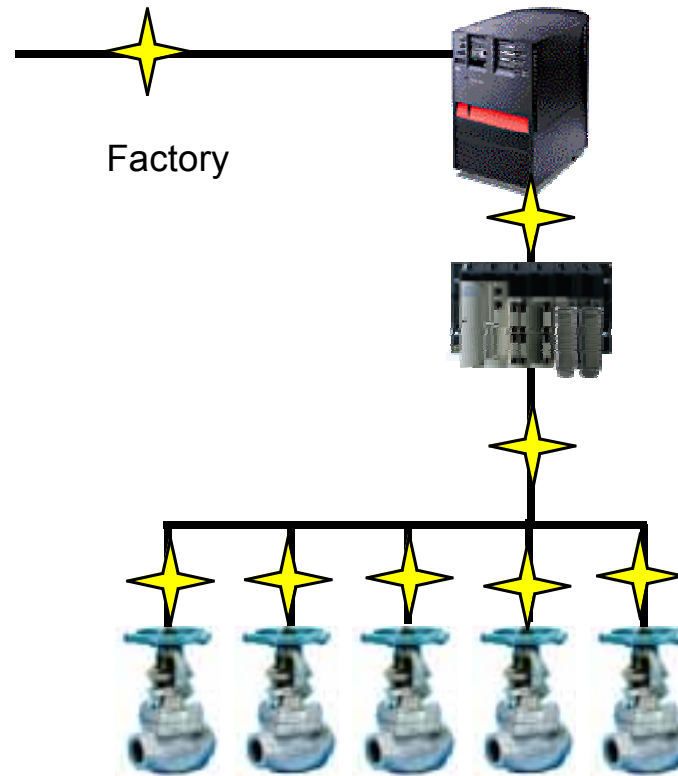
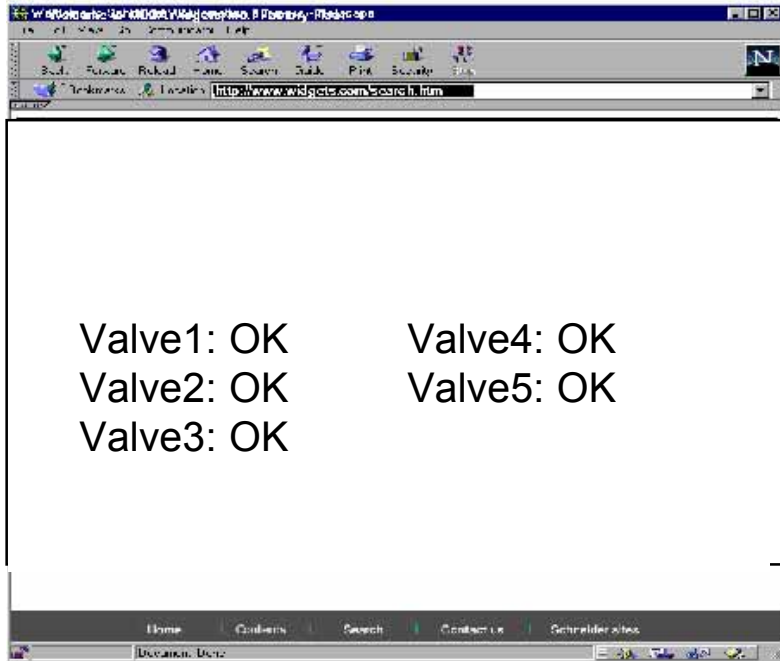

Plant Manager

This summer, our web-enabled catalog grow from 50 to 70 products !



AC Inverters ATV 58



Switches,
Hubs & Bridges

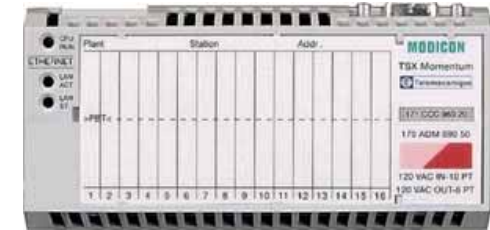

New miniaturized PLC



New PLC communications coplers

Transparent
FACTORY
Open for Business



Synerg *e*2000

the power of partnering



Synerge 2000 Nashville is a global conference and EXPO event showcasing solutions from Schneider Electric & Partners for the Process to Business e-manufacturing

500 - 700 Attendees

2 1/2 Day Conference and Expo

Opryland Hotel and Convention Center

Held on October 16 - 18, 2000



Our vision is ...



Transparent
FACTORY™
Open for Business

We lead Web-Automation
Schneider Electric Automation Business



Schneider Electric 2000+ Growth, competitiveness and new ways of working

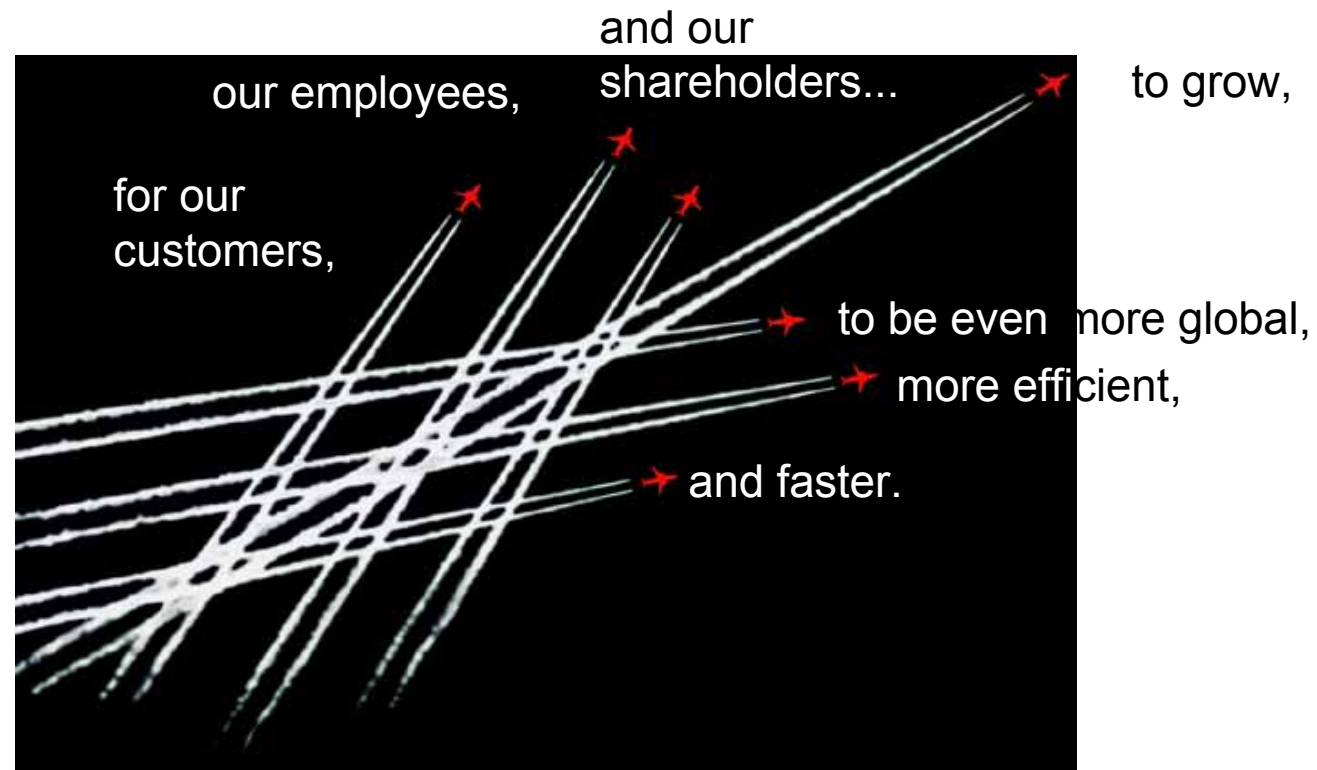

**Accelerate profitable growth.
Further reduce cost.
Encourage practice supporting company targets.**

